

VINTAGE

TEN, TWELVE & FIFTEEN

FYNE ADVICE

ESSENTIAL INFORMATION GUIDE



FYNE
VINTAGE

TABLE OF CONTENTS

1. Introduction
2. Technology
3. Unpacking
4. Positioning & fitting floor coupling spikes
5. Amplifier choice
6. Cable choice
7. Connecting speaker cables
8. Earth connections
9. Adjustments
10. Care of cabinet
11. Warranty
12. Specification

1 INTRODUCTION

Thank you for choosing Fyne Audio Vintage loudspeakers, proudly designed by our experienced team of engineers, and constructed to the highest standards by artisans in our own facility in Scotland. We believe they will give you many years of listening pleasure.

- Before installing these loudspeakers please read this manual in full, both for safety reasons and to ensure you achieve the best performance possible.
- When unpacking, please follow the instructions carefully, to avoid causing possible injury or damage. Please ensure you have the help of an assistant.
- Please retain packing for possible future use.
- Check contents of the accessories box

Your accessories box includes

- Floor coupling spike M12 (x8)
- Spike locking wheel (x8)
- Floor protection cups (x8)
- Tin wood wax (x1)
- Bi-wire links (x4)

2 TECHNOLOGY

Our experienced team of acoustic and product design engineers have been in the loudspeaker industry for very many years. Since coming together to form Fyne Audio, they have been augmenting their existing skills and developing new technologies to ensure that we can offer best in class performance through technical innovation and advanced manufacturing techniques.

The new Fyne Vintage Series takes the cutting-edge modern technology first developed by Dr Paul Mills for the award-winning F1 Series and distils it into timeless and distinctive period designs with a modern twist, that has influenced his journey to the industry leading expert he is today.

ISOFLARE™ POINT SOURCE DRIVER

Fyne Audio's IsoFlare™ driver is a point source system whereby the bass / midrange driver shares a common centre with the high frequency unit. Providing outstanding stereo imaging even off axis, energy is radiated isotropically with constant directivity following the flare of the driver cone. Sound is produced emanating from a single point.

To fully optimise the driver performance, every aspect of this meticulous design has been considered. Eliminating unwanted vibrations which would be detrimental to the sound quality, our IsoFlare™ point source drivers are built around a custom tooled rigid cast aluminium chassis. A vented rear chamber in the substantial Neodymium HF magnet places low frequency resonance well below the

crossover region. Pushing the break up mode well above the level of human hearing, the highly rigid 75mm titanium alloy high frequency diaphragm delivers a smooth and extended response, while a copper shorting ring provides low distortion. The unique geometry of the high frequency unit's waveguide provides a flat frequency response and avoids internal reflections. The HF diaphragm provides a natural and unstressed performance, terminated by a Mylar surround to optimally terminate energy. Such a large diaphragm allows a very low crossover frequency of 750Hz to the bass / midrange cone, ensuring much of the vocal range is handled by the tweeter.

The HF unit annular waveguide has a computer optimised expansion rate and geometry to provide flat frequency response and avoid internal reflections, while the high power edgewound aluminium HF voice coil on Kapton® former eliminates thermal compression.

On the low frequency section, the FyneFlute™ surround effectively terminates cone energy, without time-smearing. A multifibre paper cone gives natural sounding midrange and clean transient behaviour, while the high power LF motor system uses ferrite magnet, with rectangular copper voice coil on an aluminium former, to aid power dissipation. A copper shorting ring on the pole piece reduces eddy currents, reducing midrange distortion tenfold.

CROSSOVER

Although simple in topology, the design is computer optimised, fine tuned subjectively by critical auditioning.

The crossover makes use of high quality precision components, including low loss LF laminated iron core inductors, non-inductive thick film resistors and extremely high grade HF polypropylene capacitors. High quality gold plated WBT Nextgen™ bi-wire terminals are used, together with high quality OFC wiring for transparent signal transfer. The components are hard wired on fibre board panels to minimise vibration, using a special mastic.

A specially designed autotransformer using the highest grade silicon steel laminations impedance matches the HF compression driver to the amplifier, with varnish vacuum impregnation to eliminate distortion caused by winding vibration.

Cryogenic treatment of the complete crossover relaxes stresses in materials and solder joints to maximise signal transparency. A grounding terminal is fitted to minimise the effect of radio frequency interference masking fine detail.

BASSTRAX™ TRACTRIX DIFFUSER SYSTEM

The Vintage Series employs a downwards firing port arrangement using a twin cavity reflex loading system. This loading system broadens the tuning frequency to reduce cone excursion, and acts as a muffler, blocking standing waves produced by the main internal port.

Below the vent in the base of the loudspeaker, the BassTrax™ Tractrix profile diffuser is used to convert the plain wave energy to an expanding spherical 360-degree wavefront, dispersing energy uniformly into the room. This Tractrix profile has been previously applied to horn loudspeakers by Voight in the 1920's, but the application to a diffuser of this type is novel and has been granted a patent.

The BassTrax™ Tractrix profile is known to maintain a 90 degree angle at each intersection of the expanding wavefront, thus avoiding reflections. This clever arrangement also makes the loudspeaker less critical of room positioning.

ENCLOSURE

The high density birch ply construction is pressed to ensure an extremely rigid and low colouration structure. The drive unit is coupled to internal bracing panels through damping material to absorb energy. Each cabinet is uniquely crafted from individually selected Walnut and Burr Walnut real wood and accented with gold anodised metalwork.

Heavy duty support spikes enable precise levelling, with the provision of machined aluminium cups for protection on wooden floors.

3 UNPACKING

This operation should be performed by two people to avoid injury or damage to the loudspeaker, should it slip or fall.

Vintage Twelve and Fifteen: these are shipped on wooden pallets. After removing the cardboard lid, foam top cushion and cardboard sleeve, lift the loudspeaker off the wooden pallet, using the straps provided (Fig. 1). The speaker can then be slid roughly into position, while sitting on the foam bottom end cushions.

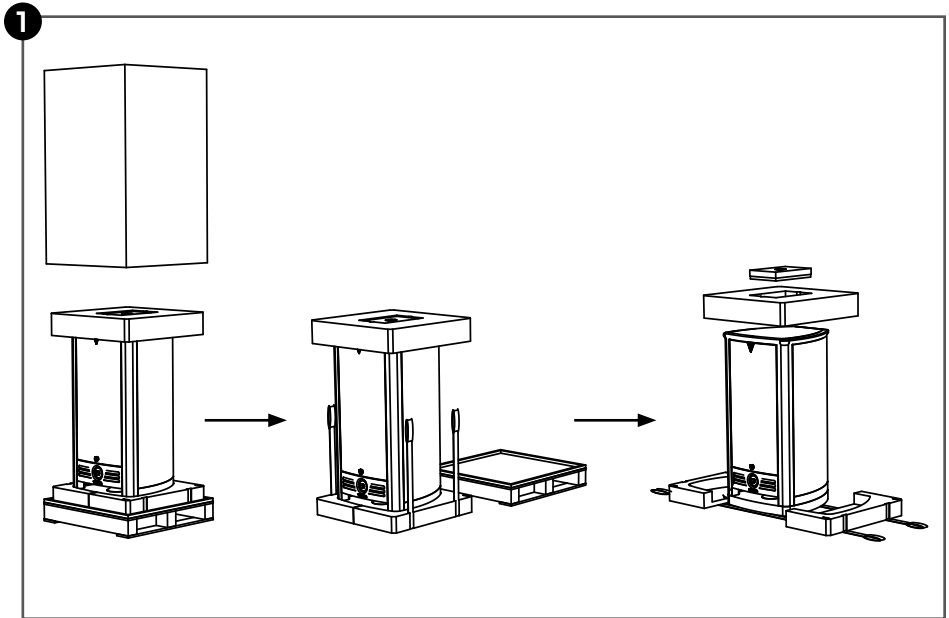

4 POSITIONING & FITTING FLOOR COUPLING SPIKES

With the loudspeaker still located on the foam end cushions, start by positioning the loudspeakers with their rear at least 0.5m from the rear wall. The proximity of a side wall should be no closer than 1m (Fig. 2).

Remember that proximity to the rear and side wall will influence both the bass performance and stereo imaging. Excessively reflective or dissimilar adjacent walls will be detrimental to the stereo image precision. The imaging focus is influenced by toeing in the cabinets towards the listening position. The BassTrax™ diffuser system however, will serve to make the loudspeaker less sensitive to boundary conditions than with a conventional design.

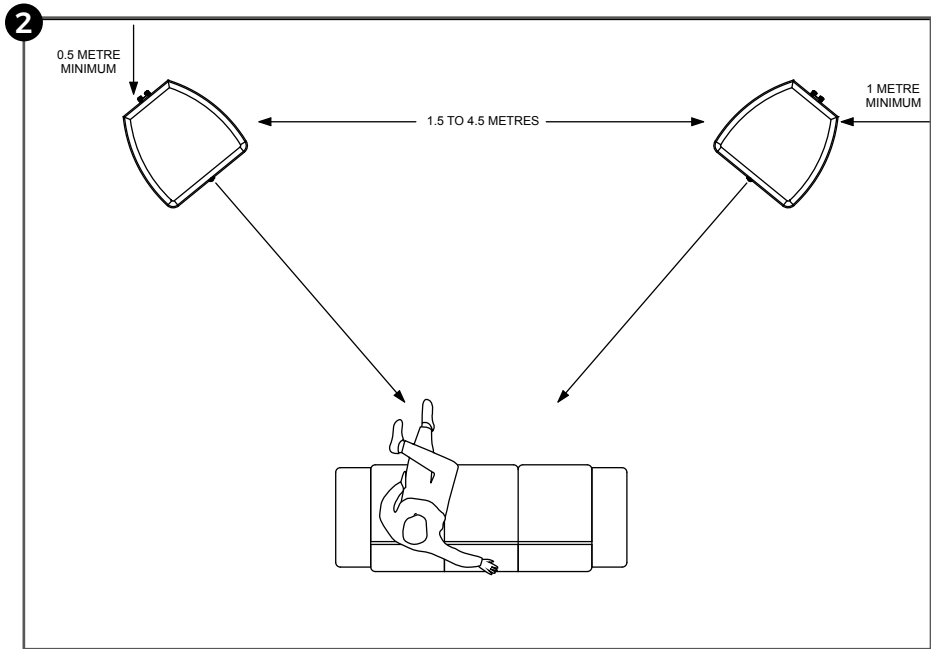

Vintage Twelve & Fifteen: referring to Fig. 3, with the help of an assistant, remove the foam end cushion from one side of the loudspeaker, and fit two of the floor coupling spikes and locking wheels. Repeat for the other side of the loudspeaker.

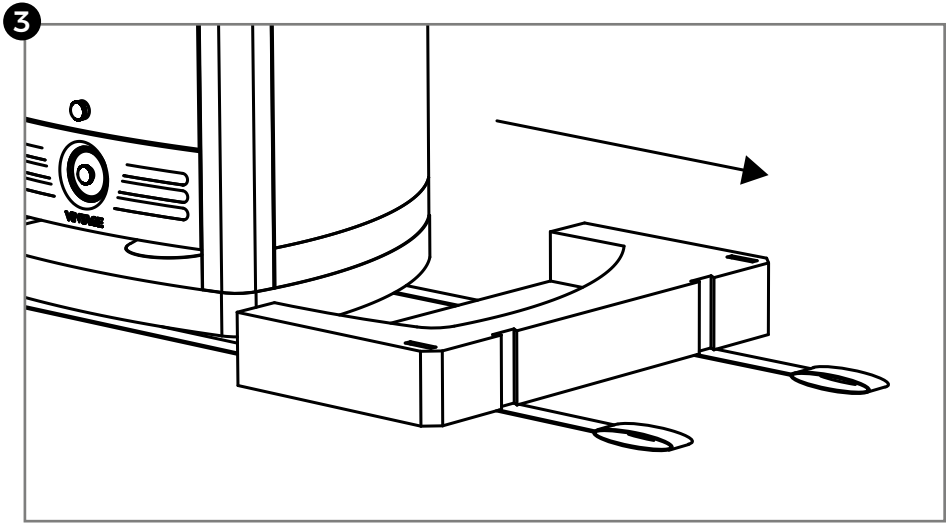

Vintage Ten: lift the loudspeaker off the foam end cushions and fit the 4 floor coupling spikes and locking wheels. When the loudspeaker is in position, level by adjusting the spikes and tighten the locking wheels (Fig. 4).

Ensure the protective cups are used under the spikes to avoid damage to wooden or other delicate floor surfaces.

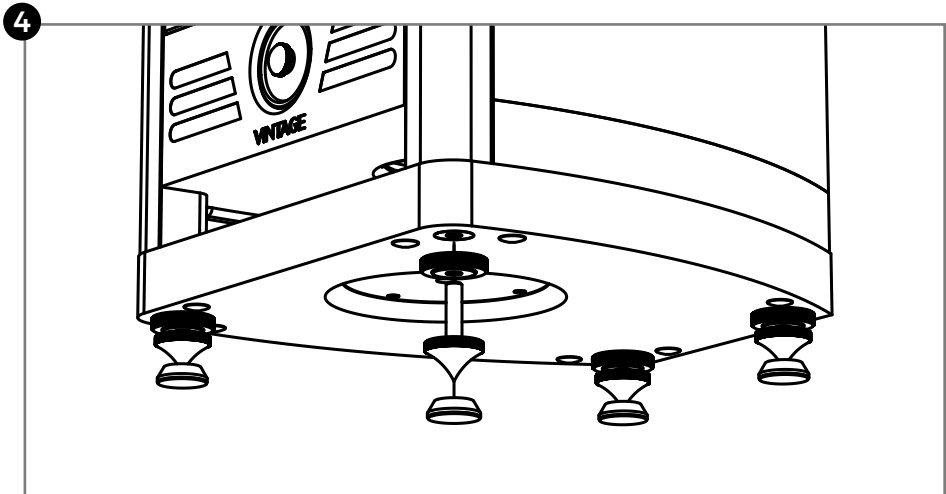

5 AMPLIFIER CHOICE

The advisable range of amplifier powers is detailed in the Specification. Responsible use with higher powered amplifiers is possible, due to the robust design of these loudspeakers.

We do not advocate any specific amplifier technology, i.e. transistor versus valve (tube). As with any high resolution loudspeaker system, it is the quality of the amplification that is paramount in extracting maximum performance from your loudspeakers. Some customers may wish to use valve (tube) amplifiers such as single ended triodes, with output powers less than the minimum recommendation. This will not cause damage to the loudspeakers, but will restrict the maximum volume and dynamic range, especially in large rooms.

If you are considering the purchase of a new amplifier, your dealer will be able to give you recommendations that work well.

6 CABLE CHOICE

It is important to use cables of appropriate quality for such high performance loudspeakers. While from a technical perspective, an adequately low electrical resistance is necessary to minimise losses and maximise amplifier damping. The physical construction of the cable including conductor type and purity, together with insulation characteristics have considerable influence on the sound quality. The optimum cable is both subjective and system dependent; your dealer will be able to give advice.

Cables should be terminated in high quality connectors, either 4mm banana or spade. We would recommend the use of WBT Nextgen™ connectors.

7 CONNECTING SPEAKER CABLES

Ensure the amplifier is switched off before connecting cables, to avoid damage.

Ensure connections are made positive to positive and negative to negative between the loudspeaker and the amplifier.

The loudspeakers are provided with two sets of terminals, one for the HF and one for the LF section. Wiring may be done in either single wire mode or bi-wire mode. The latter will provide optimum performance.

When using a single cable, wire as shown (Fig. 6), fitting the link cables provided. The best sound quality will generally be achieved when connecting to the HF terminals. For bi-wire operation, ensure the link wires are not fitted, and wire with two sets of cable, or a dedicated bi-wire cable (Fig. 7). This will ensure the best possible sound quality.

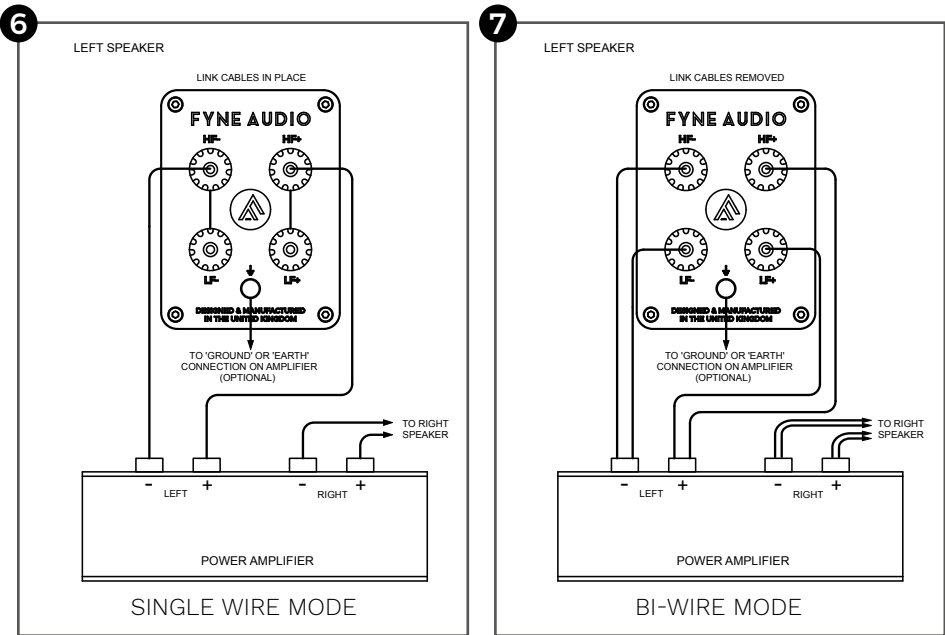

A further option is bi-amping, where the LF and HF sections of the loudspeaker are each driven from their own amplifier, for further enhancement in sound quality. Either two stereo power amplifiers or four monoblock amplifiers may be used. If using either two stereo power amplifiers or four

monoblock amplifiers may be used. If using two stereo amplifiers, it is recommended that one is used as the LF channel to both loudspeakers and the other HF (Fig. 8).

To avoid amplifier damage, the bi-wire link cables must not be in place.

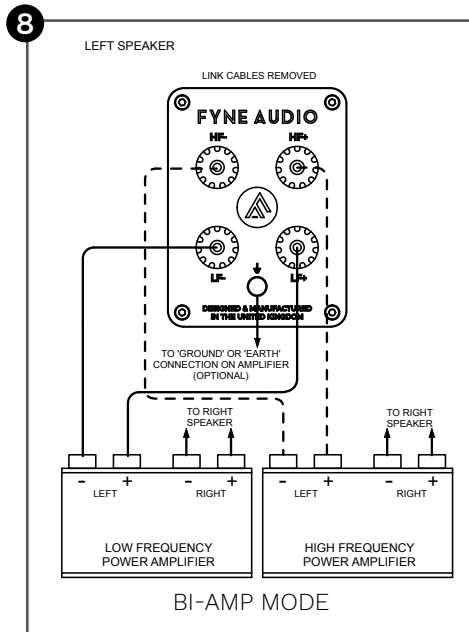

8 EARTH CONNECTION

The loudspeaker is provided with an earth or ground connection, connected to the drive unit chassis. The purpose of this is to ground any radio frequency interference that may get back to the amplifier, reducing fine detail and resolution. A separate earth wire may be used for this purpose, but best results will be obtained by using a dedicated screened loudspeaker cable.

9 ADJUSTMENTS

The Vintage Series is provided with two adjustment controls on the front panel, to achieve optimal performance in terms of both the listening environment and listener preference.

The upper 'Energy' control alters the level of signal fed to the tweeter, from the crossover point upwards, giving control over how bright the presentation sounds (Fig. 9).

The lower 'Presence' control only affects the lower treble region of 2.5 - 5.0kHz, and influences articulation and vocal clarity and having an effect on image depth (Fig. 10).

Start with both controls in the central (level) position, and make small adjustments with well recorded programme material that you are familiar with. Achieving the correct presentation is equivalent to focusing the lens on a camera, to achieve the most realistic sound-staging depth.

9 HF ENERGY ADJUSTMENT

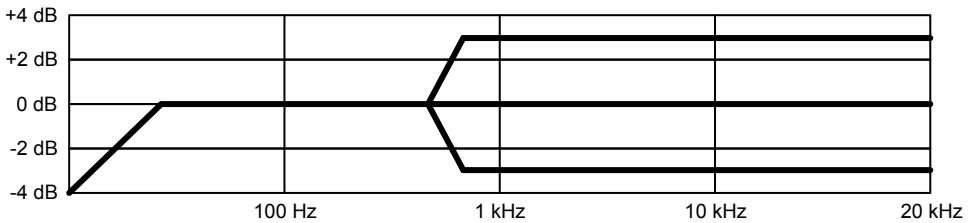

10 PRESENCE ADJUSTMENT

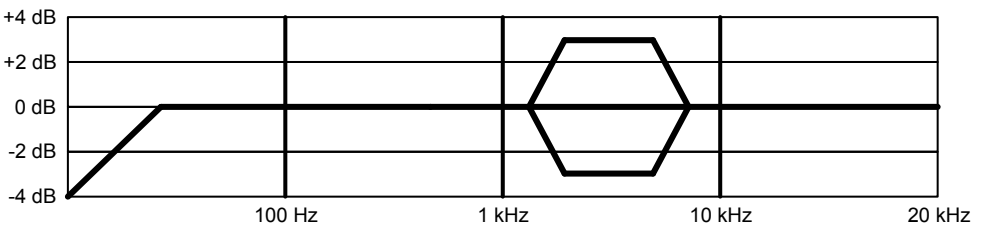

10 CARE OF CABINET

The cabinet may be dusted with a lint free cloth, such as muslin. As wood is a natural material, avoid exposure to extremes of heat, humidity and direct sunlight for extended periods of time.

If unused for long periods of time, you may wish to cover the loudspeakers with the cloth bags they were packaged in, to provide protection.

On no account use solvents or abrasive materials, as this will cause damage and invalidate the warranty.

The oiled walnut body of the cabinet should be treated sparingly with the wood wax provided, using a lint free cloth. This should be done several times a year or when the oiled finish shows signs of drying out, depending on temperature and humidity. Avoid contact with the front baffle and grille cloth.

CAUTION:

- Wood wax contains ALPHA PINENE- may produce an allergic reaction
 - Flammable- flash point 38 degrees celcius
 - Keep out of reach of children
 - Use in a well ventilated area. Never eat, drink or smoke during use
 - Vapours may cause drowsiness or dizziness. In the case of excessive inhalation, remove the person exposed to fresh air, keep warm and at rest
 - In the event of eye contact, rinse with clean water for 15 minutes
 - In the event of skin contact, wash thoroughly with soap and water
 - If swallowed, seek medical advice immediately and show this information
 - Do not empty into drains, but dispose of in accordance with local regulations.
- Dispose of used cloths carefully**
- Keep the container tightly closed and store in a dry well ventilated place

11 WARRANTY

For the latest product news and information, please visit www.fyneaudio.com.

All Fyne Audio products purchased from an authorised distributor or retailer are covered by a manufacturer's warranty, subject to presentation of a valid proof of purchase. This warranty is provided in addition to, and does not affect, your statutory rights as a consumer under applicable national or local laws.

Full warranty terms and conditions are available at www.fyneaudio.com/warranty. Alternatively, you may request a copy or obtain further assistance by contacting our Customer Service Department by telephone on +44 (0)141 428 4008 (charges may apply for calls made from outside the UK), by email at enquiries@fyneaudio.com, or by post at:

Fyne Audio Limited
No. 1 Cubitt Court
Belgrave Street
Bellshill
North Lanarkshire
ML4 3NP
United Kingdom

12 SPECIFICATIONS

	VINTAGE TEN
System type	2 way, downwards firing port, with BassTrax™ Tractrix diffuser
Recommended amplifier power (Watt RMS)	20 - 280
Peak power handling (Watt peak)	560
Continuous power handling (Watt RMS)	140
Sensitivity (2.83 Volt @ 1m)	94dB
Nominal impedance	8 Ohm
Frequency response (-6dB typical in room)	26Hz- 26kHz
Drive unit complement	1 x 250mm IsoFlare™ point source driver, multi-fibre bass / midrange cone, with 75mm titanium alloy dome compression tweeter, neodymium magnet system
Crossover frequency	750Hz
Crossover type	Bi-wired passive low loss, 2nd order low pass, 2nd order high pass, Deep Cryogenically Treated
System adjustments	High frequency energy (750Hz - 26kHz) +/- 3dB Presence (2.5kHz - 5.0kHz) +/- 3dB
Dimensions - HxWxD	1040 x 468 x 489mm (40.9 x 18.4 x 19.3")
Cabinet construction	Birch ply with oiled walnut and solid walnut trim, extensive internal bracing

VINTAGE TWELVE

System type	2 way, downwards firing port, with BassTrax™ Tractrix diffuser
Recommended amplifier power (Watt RMS)	20 - 350
Peak power handling (Watt peak)	700
Continuous power handling (Watt RMS)	175
Sensitivity (2.83 Volt @ 1m)	96dB
Nominal impedance	8 Ohm
Frequency response (-6dB typical in room)	24Hz- 26kHz
Drive unit complement	1 x 300mm IsoFlare™ point source driver, multi-fibre bass / midrange cone, with 75mm titanium alloy dome compression tweeter, neodymium magnet system
Crossover frequency	750Hz
Crossover type	Bi-wired passive low loss, 2nd order low pass, 2nd order high pass, Deep Cryogenically Treated
System adjustments	High frequency energy (750Hz - 26kHz) +/- 3dB Presence (2.5kHz - 5.0kHz) +/- 3dB
Dimensions - HxWxD	1102 x 572 x 591mm (43.4 x 22.5 x 23.3")
Cabinet construction	Birch ply with oiled walnut and solid walnut trim, extensive internal bracing

12 SPECIFICATIONS

VINTAGE FIFTEEN

System type	2 way, downwards firing port, with BassTrax™ Tractrix diffuser
Recommended amplifier power (Watt RMS)	20 - 400
Peak power handling (Watt peak)	800
Continuous power handling (Watt RMS)	200
Sensitivity (2.83 Volt @ 1m)	97dB
Nominal impedance	8 Ohm
Frequency response (-6dB typical in room)	22Hz- 26kHz
Drive unit complement	1 x 380mm IsoFlare™ point source driver, multi-fibre bass / midrange cone, with 75mm titanium alloy dome compression tweeter, neodymium magnet system
Crossover frequency	750Hz
Crossover type	Bi-wired passive low loss, 2nd order low pass, 2nd order high pass, Deep Cryogenically Treated
System adjustments	High frequency energy (750Hz - 26kHz) +/- 3dB Presence (2.5kHz - 5.0kHz) +/- 3dB
Dimensions - HxWxD	1152 x 683 x 691mm (45.4 x 26.9 x 27.2")
Cabinet construction	Birch ply with oiled walnut and solid walnut trim, extensive internal bracing

Thank you for choosing Fyne Audio loudspeakers, proudly designed by our experienced team of engineers in Scotland, and constructed to the highest standards.

WWW.FYNEAUDIO.COM

f FYNEAUDIO

X @FyneAudio

This information was correct at the time of print, for our most recent products and information visit www.fyneaudio.com